



K-LITE **POOL**

Recessed

High efficiency LED underwater luminaire for illumination of medium and large swimming pools, water features and fountains, revealing underwater architecture. Recessed and Surface mounted version is available in different CCT options including RGB, creating special lighting effects.



Recessed Pool LED Luminaires



Surface Mounted LED Spot Light



LED Fountain Light



Product Benefits

- High luminous efficiency at reduced wattage.
- A sleek and minimalist shape provides distinctive lighting effects.
- Sustainable LED technology offers durability and optimal light output with low power consumption.

Area of Application

Fountains, Swimming pools, Water features and other similar applications.

Note : It is our constant endeavor to upgrade the performance of our products. For the latest technical information, IES files and product updates please refer to the website www.klite.in



Important Note : To ensure proper installation, kindly translate / communicate the installation instructions to a qualified electrician in their respective local language.



Product Description

- Complete housing made of marine grade stainless steel #316
- PCB made of excellent heat conductivity aluminium $\geq 2.0w/mk$
- Luminaire hard wired for single colour 2 x 1.0mm² / RGB 4 x 0.75 mm² 3 metres water resistant cable.
- Recommended installation depth upto 1 metre below the water surface.



Technical Specifications

General

ID : 4129 / 4130 RGB
 System Wattage : 9 x 2W LED
 Driver Mounting : Non Integral
 Operating Current : 650mA / 1000mA
 Operating Temperature : -20°C ~ +40°C
 Warranty : 2 years

Light Source

Light source : OSRAM
 LED Lumens : 2100 lm / 1170 lm
 CRI (Ra) : ≥ 80
 LED Colour Temperature : 3000K

Physical

Body : Marine grade SS 316
 Diffuser : Step Tempered Glass T=8mm
 Gasket : Silicone

Driver Options

Remote Driver : 12V DC
 Dimmable : Dali / RGB - DMX-On Request

Optical

Colour Temperature : 3000K / RGB
 Luminous flux : 865 / 580 lm
 Beam Angle : 20°
 Optical Lens Efficiency : $>85\%$



Light Distribution

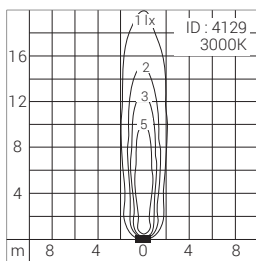

Applied Photometry : H=1m

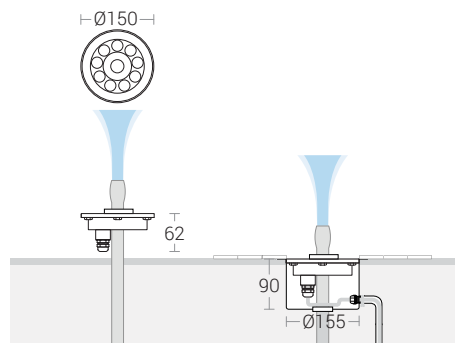

Size : Water Jet Pipe G(PF)3/4 Taper